

Remote Access Gateway IGW/925 with DIL/NetPC ADNP/9200

First Steps



SSV Embedded Systems

Dünenweg 5
D-30419 Hannover
Phone: +49 (0)511/40 000-0
Fax: +49 (0)511/40 000-40
E-mail: sales@ssv-embedded.de

Document Revision: 1.3
Date: 2013-08-20

CONTENT

1	INTRODUCTION	3
1.1	Checklist	3
1.2	Usage	3
1.3	Conventions	3
2	SAFETY GUIDELINES	4
3	HARD- AND SOFTWARE REQUIREMENTS	5
4	CONNECTIONS	6
4.1	RS232 Serial Link	6
4.2	Ethernet Link	7
4.3	Power Supply	8
5	OPERATION	9
5.1	Serial Connection	9
5.2	Booting the Embedded Linux	11
5.3	Testing the TCP/IP Communication	13
5.4	Accessing the SSV Web ConfigTool	15
5.5	Access via Telnet	16
5.6	Changing the IP Address	17
6	INFORMATION IN THE INTERNET	18
7	MAINTENANCE	19
8	DISPOSAL	19
9	TROUBLE SHOOTING	19
10	TECHNICAL DATA	20
11	EMC INFORMATION	20
12	PINOUT SCREW TERMINALS	21
13	HELPFUL LITERATURE	22
	CONTACT	22
	DOCUMENT HISTORY	22

1 INTRODUCTION

With the Remote Access Gateway IGW/925 with DIL/NetPC ADNP/9200 you bought a system, which introduces you in the various types of use of a Linux-based 32-bit embedded system.

This documentation gives you an overview about the initial operation and the first steps of use with your new Remote Access Gateway IGW/925.

1.1 Checklist

Compare the content of your Remote Access Gateway start-up package with the checklist below. If any item is missing or appears to be damaged, please contact SSV.

- ✓ Remote Access Gateway IGW/925 with DIL/NetPC ADNP/9200
- ✓ Documentation
- ✓ CD-ROM
- ✓ Adapter cable with power and RS232 connector
- ✓ Null modem cable
- ✓ Plug-in power supply
- ✓ Screwdriver



Note: For operation you will need a 12 – 24 VDC DIN-rail power supply and at least one Ethernet patch cable!

1.2 Usage

On the one hand this Remote Access Gateway is suitable to go the first steps in the field of home automation. On the other hand it can be used also for full industrial and process automation applications.

Because of the usage of our popular DIL/NetPC as basis, the Remote Access Gateway IGW/925 offers – besides the formidable features of performance – an extraordinary high modularity (QIL-128 form factor).

1.3 Conventions

Convention	Usage
bold	Important terms
<i>italic</i>	Filenames, user inputs
monospace	Pathnames, program code, command lines

Table 1: Conventions used in this document

2 SAFETY GUIDELINES



Please read the following safety guidelines carefully! In case of property or personal damage by not paying attention to this manual and/or by incorrect handling, we do not assume liability. In such cases any warranty claim expires.

- To provide the Remote Access Gateway with power an external DIN-rail power supply is needed. The power supply should be in immediate proximity to the Remote Access Gateway.
- The power supply must provide a stable output voltage between 12 - 24 VDC. The output power should be at least 2.5 W.
- Please pay attention that the power cord or other cables are not squeezed or damaged in any way when you set up the Remote Access Gateway.
- The installation of the Remote Access Gateway should be done only by qualified personnel.
- Discharge yourself electrostatic before you work with the Remote Access Gateway, e.g. by touching a heater of metal, to avoid damages.
- Stay grounded while working with the Remote Access Gateway to avoid damage through electrostatic discharge.
- The case of the Remote Access Gateway should be opened only by qualified personnel.

3 HARD- AND SOFTWARE REQUIREMENTS

To work with the Remote Access Gateway IGW/925 a software development environment is needed.

This development environment requires a computer as development system to access the Remote Access Gateway via serial console or Telnet. Therefore usually a PC with Intel Pentium or AMD processor under Windows or Linux is used. This PC should comply with the following hard- and software requirements:

- Windows XP / 7 / 8 or Linux
- Serial (COM) interface
- Terminal program (HyperTerminal or Minicom)
- 10/100 Mbps Ethernet network controller and TCP/IP configuration
- Web browser
- Telnet client
- CD-ROM drive

Please check which IP address your PC actual has. Keep this address in mind.

On a Linux-PC just open a shell console and enter `ifconfig`. On a Windows-PC please open a DOS window (you can find it in the Windows Start menu) and enter: `ipconfig`. Now the IP address is displayed in the DOS window.



Note: With a Linux-PC as development system it is possible to develop programs in all languages for the IGW/925. Linux is especially for programming in C/C++ as PC operating system required because of the GNU cross tools. With a Windows-PC the shell-script programming as well as the HTML- and Java-applet programming of the Web server is possible.

4 CONNECTIONS

For a quick and easy start with the Remote Access Gateway IGW/925 there are several connections necessary. The following chapters describe how these connections between the development system (host PC) and the IGW/925 have to be made.

4.1 RS232 Serial Link

For a basic communication with the IGW/925 use the null modem cable and connect the **COM1** port of the IGW/925 with the COM port of your host PC.

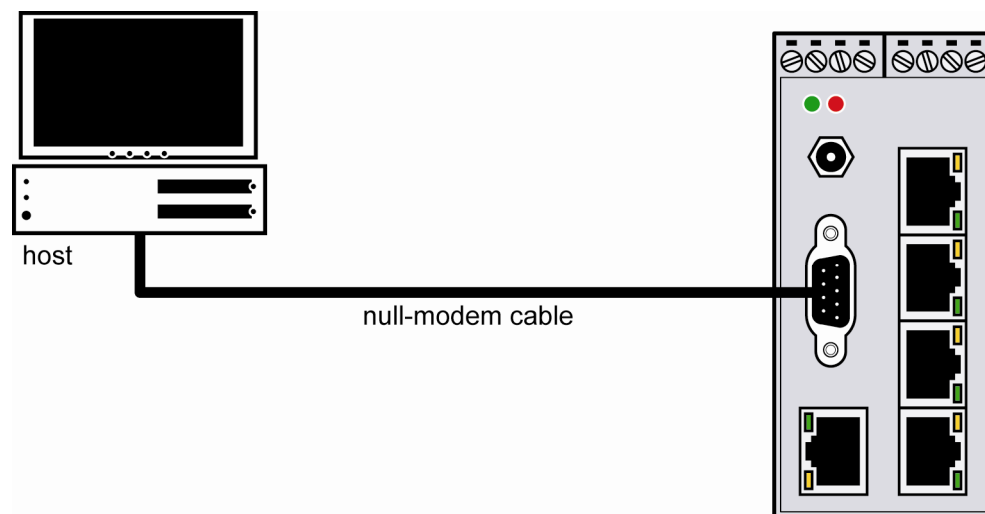

Figure 1: RS232 link on serial port COM1

4.2 Ethernet Link

For an Ethernet link just connect a standard Ethernet patch cable with an Ethernet LAN interface of your host PC and one of the LAN1 interfaces of the IGW/925 like shown **fig. 2**.

The LAN interfaces 1A – 1D are equal. They are connected over an integrated 4-port switch.

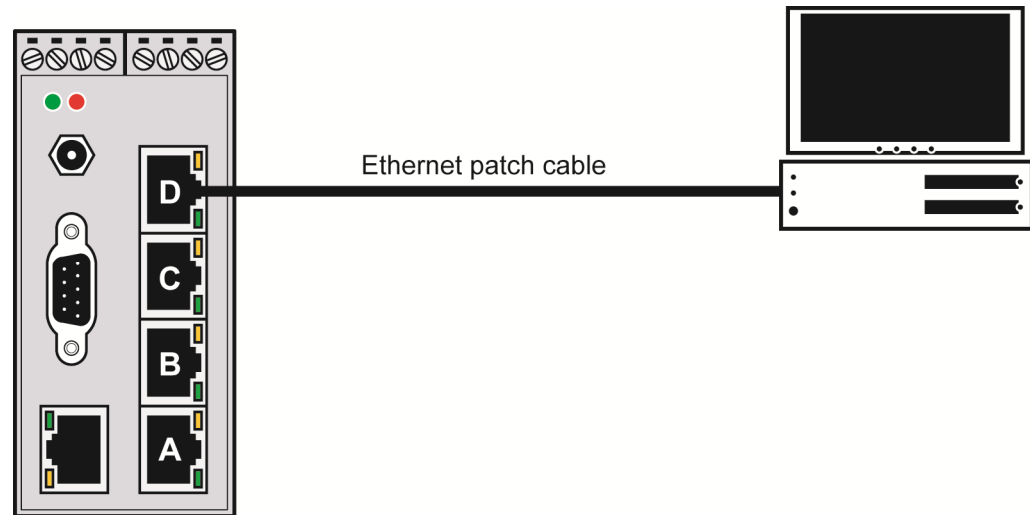

Figure 2: Ethernet link with Ethernet patch cable

4.3 Power Supply

The Remote Access Gateway IGW/925 needs a supply voltage of 11 .. 28 VDC to work. Use the power adapter cable to provide the system with the necessary power like shown in the figure below.

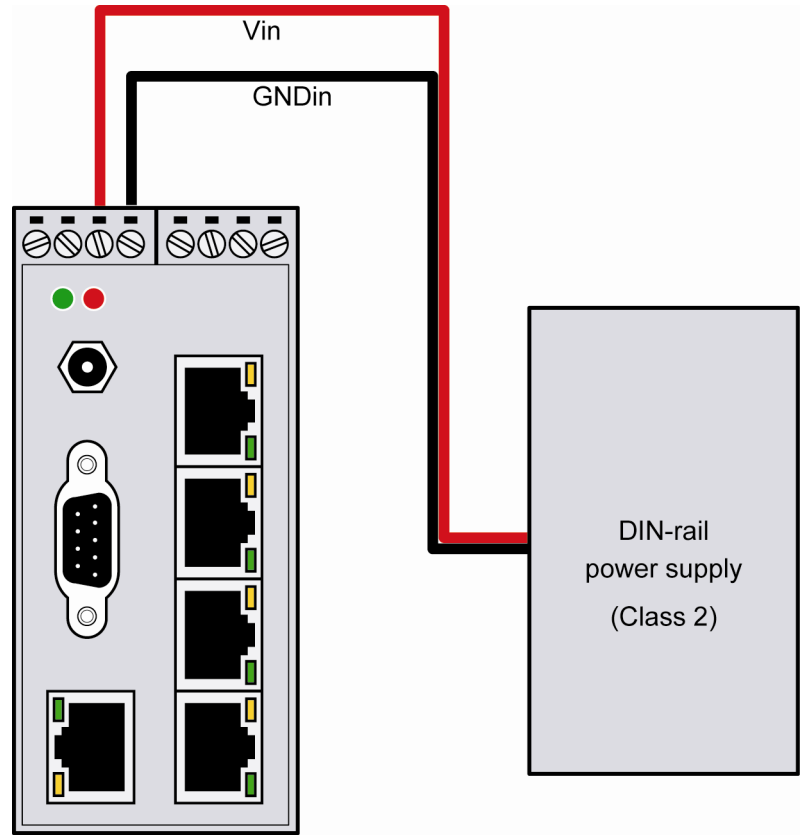
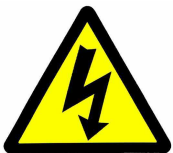

Figure 3: Power supply for the Remote Access Gateway IGW/925

Terminal	Signal
A3	Vin (11 .. 28 VDC)
A4	GNDin

Table 2: Screw terminal power



CAUTION: Providing the Remote Access Gateway IGW/925 with a higher voltage than the regular 11 .. 28 VDC could cause damaged device components!

5 OPERATION

5.1 Serial Connection

To make communication possible between the IGW/925 and the development system a terminal program is needed.

Under Windows it is normally *HyperTerminal*, for Linux exists *Minicom*, an equivalent program. In the following we use *HyperTerminal*, but all settings can be made similarly with other terminal programs. If there is no terminal program installed on your development system (this could be the case for a Linux-based PC), you have to install it manually from your operating systems installation CD-ROM.

First open a new *HyperTerminal* session and enter a name for it (e.g. *IGW/925*). Choose now under „File->Properties“ under „Connect via“ the entry „**direct link cable connection via COM1**“ (or the COM-port you used). In the next step click on the button „**configure**“ to get to the next dialog box.



Figure 4: Interface dialog box

Now change the settings to the parameters shown in **fig. 5** and close the dialog box with a click on „OK“.

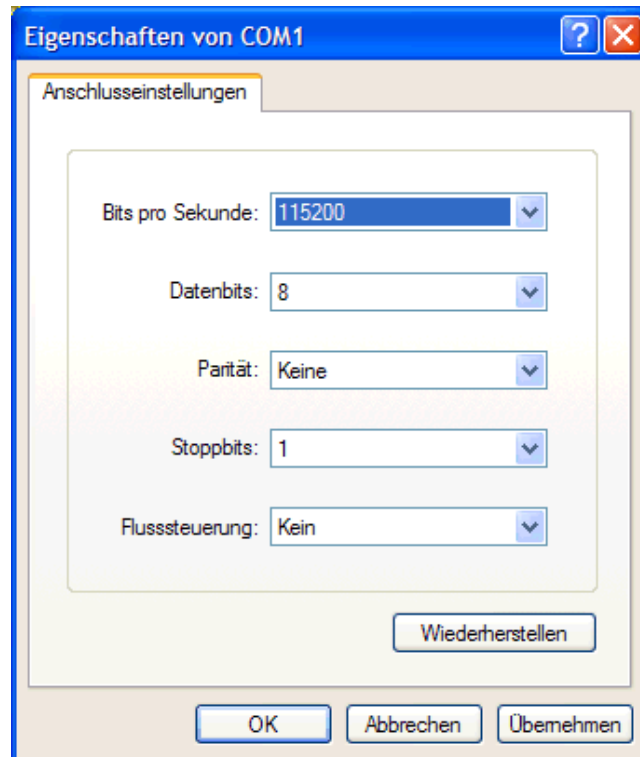

Figure 5: Communication parameter settings

These settings can also be made in other terminal programs. Important are the following parameters and values:

Parameter	Wert
Connection speed	115.200 bps
Data bits	8
Parity	None
Stop bits	1
Handshake	None

Table 3: Terminal program settings



Note: Do not forget to save the session settings with the connection parameters under the name you have chosen (e.g. *IGW/925*). With this name you can start the terminal program for future IGW/925-access.

5.2 Booting the Embedded Linux

Now you may power up the IGW/925. The boot process starts immediately. The IGW/925 boots thereby an embedded Linux out of its Flash memory. The following figure shows the corresponding messages during this procedure with the Windows terminal program *HyperTerminal*.

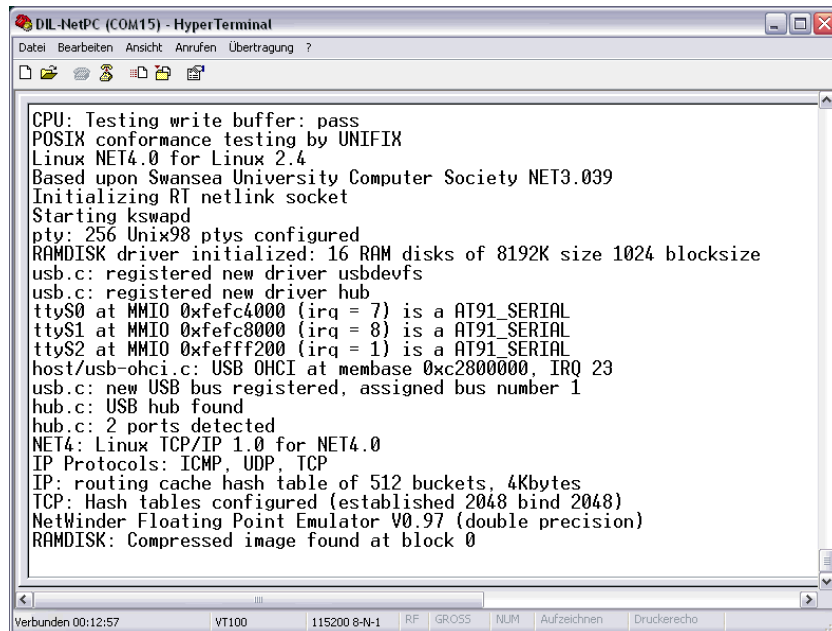

```
DIL-NetPC (COM15) - HyperTerminal
Datei Bearbeiten Ansicht Anrufen Übertragung ?
CPU: Testing write buffer: pass
POSIX conformance testing by UNIFIX
Linux NET4.0 for Linux 2.4
Based upon Swansea University Computer Society NET3.039
Initializing RT netlink socket
Starting kswapd
pty: 256 Unix98 ptys configured
RAMDISK driver initialized: 16 RAM disks of 8192K size 1024 blocksize
usb.c: registered new driver usbdevfs
usb.c: registered new driver hub
ttyS0 at MMIO 0xfefc4000 (irq = 7) is a AT91_SERIAL
ttyS1 at MMIO 0xfefc8000 (irq = 8) is a AT91_SERIAL
ttyS2 at MMIO 0xfefff200 (irq = 1) is a AT91_SERIAL
host/usb-ohci.c: USB OHCI at membase 0xc2800000, IRQ 23
usb.c: new USB bus registered, assigned bus number 1
hub.c: USB hub found
hub.c: 2 ports detected
NET4: Linux TCP/IP 1.0 for NET4.0
IP Protocols: ICMP, UDP, TCP
IP: routing cache hash table of 512 buckets, 4Kbytes
TCP: Hash tables configured (established 2048 bind 2048)
NetWinder Floating Point Emulator V0.97 (double precision)
RAMDISK: Compressed image found at block 0
Verbinden 00:12:57 VT100 115200 8-N-1 RF GROSS NUM Aufzeichnen Druckerecho
```

Figure 6: Embedded Linux boot process

The Linux boot process of the IGW/925 ends with the following command prompt:

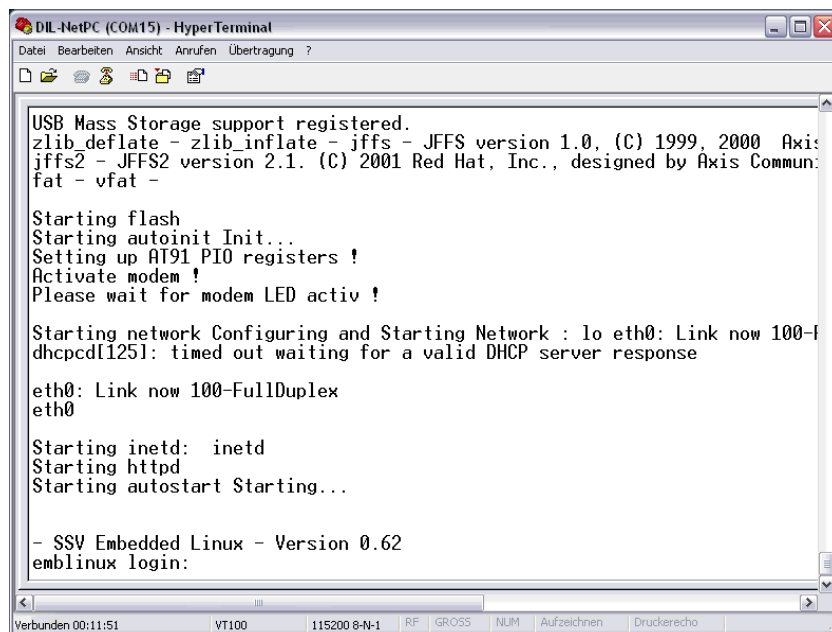

```
DIL-NetPC (COM15) - HyperTerminal
Datei Bearbeiten Ansicht Anrufen Übertragung ?
USB Mass Storage support registered.
zlib_deflate - zlib_inflate - jffs - JFFS version 1.0, (C) 1999, 2000 Axis
jffs2 - JFFS2 version 2.1. (C) 2001 Red Hat, Inc., designed by Axis Commun
fat - vfat -

Starting flash
Starting autoinit Init...
Setting up AT91 PIO registers !
Activate modem !
Please wait for modem LED activ !

Starting network Configuring and Starting Network : lo eth0: Link now 100-f
dhcpcd[1251]: timed out waiting for a valid DHCP server response

eth0: Link now 100-FullDuplex
eth0

Starting inetd: inetd
Starting httpd
Starting autostart Starting...

- SSV Embedded Linux - Version 0.62
emblinux login:
Verbinden 00:11:51 VT100 115200 8-N-1 RF GROSS NUM Aufzeichnen Druckerecho
```

Figure 7: Linux command prompt

The command prompt is a part of the serial console of the DIL/NetPC ADNP/9200 within the IGW/925. To login enter **root** as username and **root** as password. You can now enter any Linux commands, which will be executed by the DIL/NetPC operating system.

Command	Function
cat	Show file content or write input in file
cd	Change directory
chmod	Change access right for a file
cp	Copy file
ls	List directory- and filenames, access rights, etc.
mkdir	Make new directory
mv	Move file
ps	Overview of active processes
pwd	Show name of actual directory
rm	Remove file
rmdir	Remove empty directory

Table 4: Some important DIL/NetPC Linux commands

Please note that every Linux command must be confirmed with a carriage return. Some commands need additional parameters.

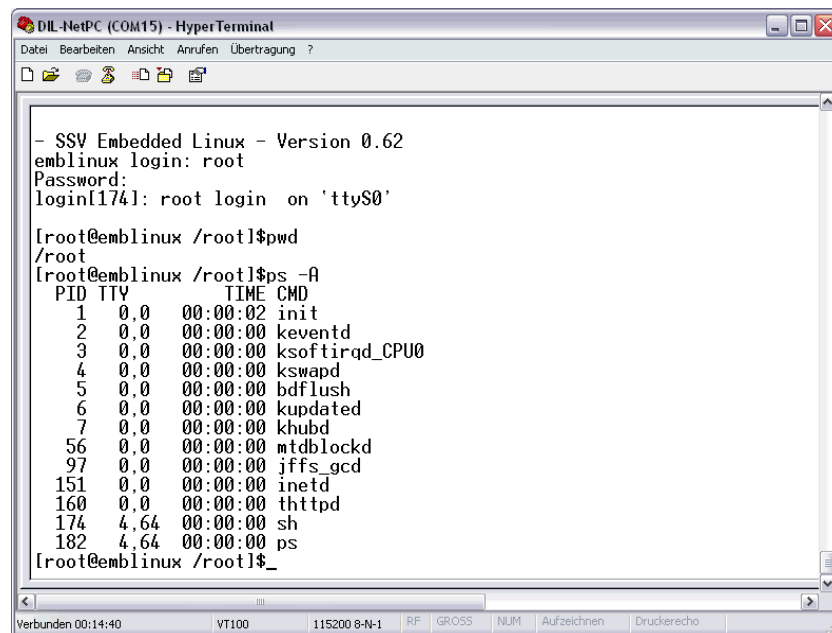

Figure 8: Executing Linux commands with a serial console



Note: The same DIL/NetPC Linux commands are also executable within the scope of a Telnet session. You will find more details in **chapter 5.5** in this manual.

5.3 Testing the TCP/IP Communication

To test the Ethernet connection on the basis of TCP/IP-protocols between the IGW/925 and the host PC we use the very popular TCP/IP-utility program *ping*. Please open a DOS window on your host PC (you can find it in the Windows Start menu) and enter:

```
ping 192.168.0.126
```

Directly after this command test data is send from the host PC to the IGW/925 via Ethernet LAN. The IGW/925 must answer on the same way within a certain period of time. **Fig. 9** shows the entry of the command as well as the successful execution. In case of an error *ping* reports a timeout.

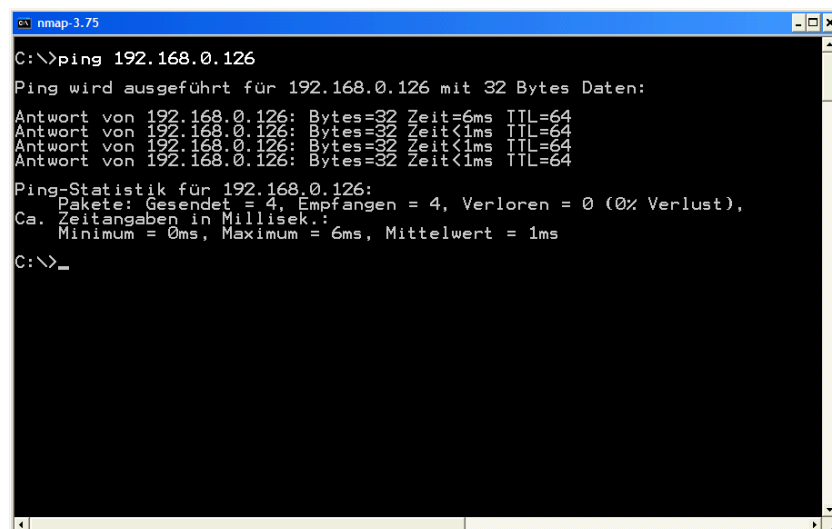

```

C:\>ping 192.168.0.126
Ping wird ausgeführt für 192.168.0.126 mit 32 Bytes Daten:
Antwort von 192.168.0.126: Bytes=32 Zeit=6ms TTL=64
Antwort von 192.168.0.126: Bytes=32 Zeit<1ms TTL=64
Antwort von 192.168.0.126: Bytes=32 Zeit<1ms TTL=64
Antwort von 192.168.0.126: Bytes=32 Zeit<1ms TTL=64
Ping-Statistik für 192.168.0.126:
    Pakete: Gesendet = 4, Empfangen = 4, Verloren = 0 (0% Verlust),
    Ca. Zeitangaben in Millisek.:
        Minimum = 0ms, Maximum = 6ms, Mittelwert = 1ms
C:\>_
    
```

Figure 9: Communication check via ping

The IGW/925 must answer every *ping*. Otherwise an error will occur. In this case you have to check all parts of your LAN connection, including the IP address of the host PC. The value of the IP address should be **192.168.0.1**. For an easy check of the IP address within the DOS window, you can use the following DOS command:

```
ipconfig
```

The **fig. 10** shows the *ipconfig*-messages of a Windows-XP-PC.



Note: We assume at this point that the IGW/925 has the ex factory IP address **192.168.0.126**. If you have changed this address, you must regard this for the *ping* parameter.

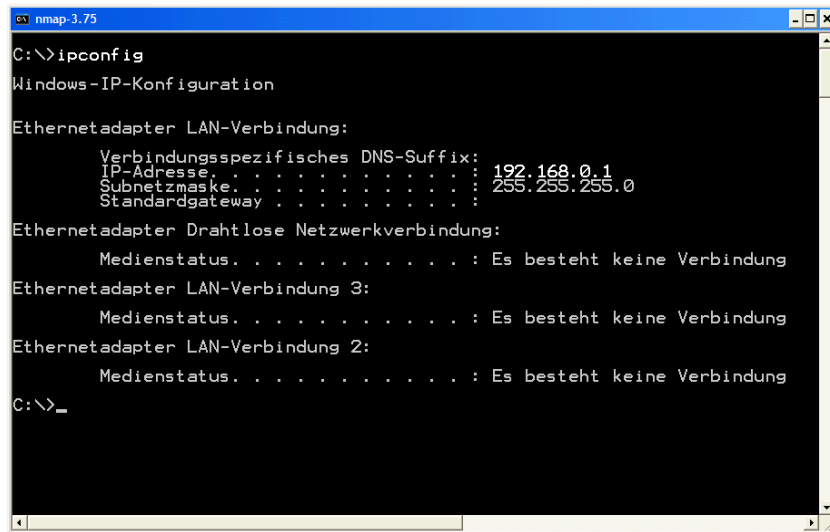

```

C:\>ipconfig
Windows-IP-Konfiguration

Ethernetadapter LAN-Verbindung:
    Verbindungsspezifisches DNS-Suffix:
    IP-Adresse. . . . . : 192.168.0.1
    Subnetzmaske. . . . . : 255.255.255.0
    Standardgateway . . . . . :

Ethernetadapter Drahtlose Netzwerkverbindung:
    Medienstatus. . . . . : Es besteht keine Verbindung
Ethernetadapter LAN-Verbindung 3:
    Medienstatus. . . . . : Es besteht keine Verbindung
Ethernetadapter LAN-Verbindung 2:
    Medienstatus. . . . . : Es besteht keine Verbindung
C:\>_

```

Figure 10: Communication check via ipconfig command

Once the *ping* was successful, you are ready to start a web browser (e.g. Firefox or Konqueror).

5.4 Accessing the SSV Web ConfigTool

To open the login page of the SSV Web ConfigTool enter this URL in a Web browser: `http://192.168.0.126:7777`.

The following passwords can be used to login:

- The default Web ConfigTool password is **adnp**. This is the standard user and has an idle timeout. The password and the timeout can be changed in the menu over “System > Administration”.
- The default Web ConfigTool master password is **ssvadmin**. This is the master user and has no idle timeout. The password can be changed in the menu over “System > Administration”.

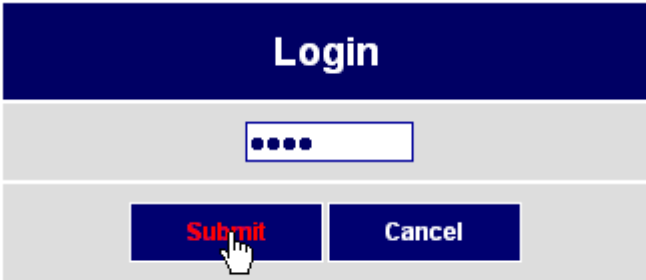

Please enter your password to access the admin page !

Figure 11: Login page of the SSV Web ConfigTool



Please note: If a standard user is already logged in, he will be automatically logged out when the master user logs in. In contrast to the standard user it is possible to log in more than once at the same time with the master password. **Although it is possible it is not recommended!**

5.5 Access via Telnet

To access the IGW/925 with a Telnet client please open a DOS window on your host PC (you can find it in the Windows Start menu) and enter the following command to activate a Telnet session:

```
telnet 192.168.0.126
```

The Linux of the IGW/925 is configured in a way, which you have to login with the user-name **root** and the password **root**.

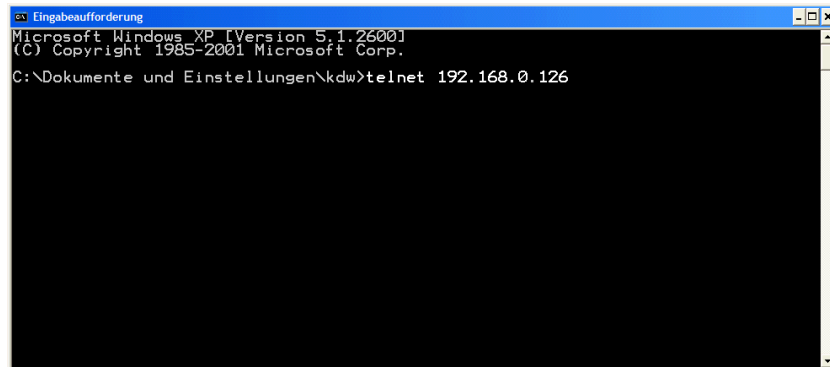

Figure 12: Starting the Telnet client

In the upcoming Telnet window you can enter any Linux commands, which will be executed by the IGW/925 operating system (similar to the serial console).

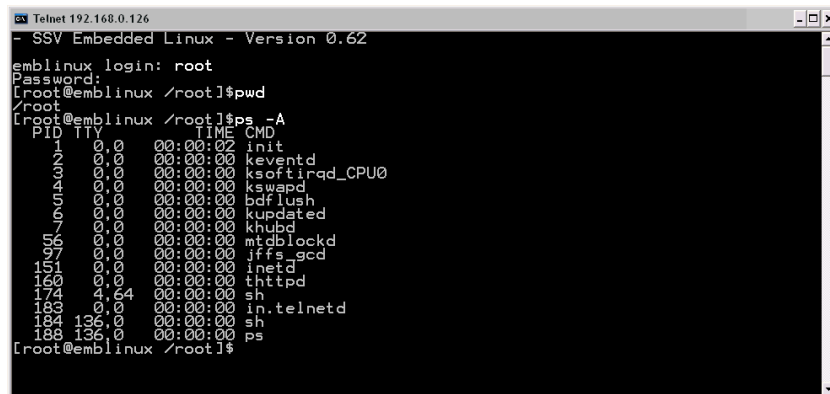

Figure 13: Access via Telnet client



Note: The Telnet command in **fig. 12** requires the current IP address of the IGW/925 as parameter.

5.6 Changing the IP Address

To change the IP address of the Remote Access Gateway enter the Web ConfigTool and choose from the menu “**Network > LAN**”. In this section you can configure the LAN settings.

Network configuration for LAN1 (10/100 MBit)		
Enable/Disable interface LAN1 :	<input checked="" type="checkbox"/>	Enable or disable interface LAN1
Obtain an IP address automatically :	<input type="radio"/>	Device configuration through DHCP server
Use the following IP address :	<input checked="" type="radio"/>	Manual device configuration
IP address :	192 . 168 . 0 . 75	Device IP address
Subnet mask :	255 . 255 . 255 . 0	Subnet mask of the local network
Enable/Disable alias IP address :	<input type="checkbox"/>	Enable or disable alias IP address

Figure 14: LAN settings

- **Enable/Disable interface LAN:** Enable or disable interface LAN.
- **Obtain an IP address automatically:** Device configuration through DHCP server.
- **Use the following IP address:** Manual device configuration.
- **IP address:** IP address of the device.
- **Subnet mask:** Subnet mask of the local network.
- **Enable/Disable alias IP address:** Enable or disable the alias IP address.
- **Alias IP address:** Secondary static IP address for the same interface.
- **Alias subnet mask:** Subnet mask of the alias network.

For more detailed information about the Web ConfigTool please read the “**SSV Web ConfigTool user manual**”.

6 INFORMATION IN THE INTERNET

To fulfil the information needs of the users, we offer the website

<http://www.ssv-comm.de/products/igw925.php>

Visit this website from time to time to access latest information.



Figure 15: IGW/925 website

On this website are also newer versions of this manual published. Please note therefore the revision number on the last page.

7 MAINTENANCE

A special maintenance for the IGW/925 is not necessary. For technical questions please send an e-mail to support@ssv-embedded.de.

8 DISPOSAL

A special disposal of the IGW/925 beyond the regulation by law is not necessary. For questions please send an e-mail to sales@ssv-embedded.de.

9 TROUBLE SHOOTING

If you experience troubles with the IGW/925 please proceed as follows:

Check all cable connections carefully. Create a serial RS232-connection – like described in **chapter 4.1** – with your development system and try to access the IGW/925 with a terminal program. Reset if necessary the IGW/925 by interrupting the power supply for a moment. Afterwards the IGW/925 should execute a new boot process, which you can watch with the terminal program.

If you still have troubles, please send an e-mail to support@ssv-embedded.de.

10 TECHNICAL DATA

Supply voltage.....	11 – 28 VDC
Weight.....	< 0,5 kg
Mechanical Dimensions (LxWxH)	112 mm x 45 mm x 100 mm
Temperature range	0° C – 70° C
Rel. air humidity.....	max. 85 %

11 EMC INFORMATION

The IGW/925 meets following EU directives about electromagnetic compatibility (EMC):

Emitted interference	
Radio disturbance	EN 55022 (industrial environment)
Interference immunity	
Case	
Radiated RF immunity	EN 61000-4-3
Electrostatic Discharge (ESD)	EN 61000-4-2
Signal connections	
Conducted RF immunity	EN 61000-4-6
Electrical fast transients/bursts	EN 61000-4-4
Direct current input and output	
Conducted RF immunity	EN 61000-4-6
Electrical fast transients/bursts	EN 61000-4-4

Table 5: EMC information



Note: Please do not connect cables longer than 3 meters with the screw terminals.

12 PINOUT SCREW TERMINALS

The **table 6** shows the pinout of the screw terminals of the IGW/925.

		Pin	Power	COM2	Alarm
A	1	A1			Alarm –
	2				
B	1	A2			Alarm +
	2				
		A3	V+ IN		
		A4	GND IN		
		B1			
		B2		TXD (RS232) RX/TX – (RS485)	
		B3		RXD (RS232) RX/TX + (RS485)	
		B4		GND	

Table 6: Pinout of the screw terminals



* **Please note:** The RS485 (officially called TIA/EIA-485-A) connection between your IGW/925 and the field devices needs termination resistors on both ends for proper operation. The IGW/925 does **not** offer internal termination resistors. Please make sure, that the RS485 cable connection is equipped with external termination resistors.

13 HELPFUL LITERATURE

- IGW/925 hardware reference manual
- DIL/NetPC ADNP/9200 hardware reference manual
- SSV Web ConfigTool user manual

CONTACT

SSV Embedded Systems

Dünenweg 5
D-30419 Hannover

Phone: +49 (0)511/40 000-0
Fax: +49 (0)511/40 000-40
E-mail: sales@ssv-embedded.de

Internet: www.ssv-comm.de
Forum: www.ssv-comm.de/forum

DOCUMENT HISTORY

Revision	Date	Remarks	Name	Review
1.0	2013-05-02	First version	WBU	FKI
1.1	2013-07-09	Fig. 2 and 3 corrected (the used LAN port was wrong)	WBU	FKI
1.2	2013-07-29	Changed cover image, edited chapters 1.1 and 4.2	WBU	FKI
1.3	2013-08-20	Edited chapter 4.2: LAN1A-D not connected with LAN2	WBU	FKI

The content of this document can change any time without announcement. There is taken over no guarantee for the accuracy of the statements. The user assumes the entire risk as to the accuracy and the use of this document. Information in this document is provided ‘as is’ without warranty of any kind. Some names within this document can be trademarks of their respective holders.

© 2013 SSV EMBEDDED SYSTEMS. All rights reserved.