

# ***Remote Access Gateway IGW/925*** *with DIL/NetPC ADNP/9200*

## **Hardware Reference**



### **SSV Embedded Systems**

Dünenweg 5  
 D-30419 Hannover  
 Phone: +49 (0)511/40 000-0  
 Fax: +49 (0)511/40 000-40  
 E-mail: sales@ssv-embedded.de

Document Revision: 1.5  
 Date: 2015-08-26



# CONTENT

---

- 1 INTRODUCTION ..... 3**
  - 1.1 Safety Guidelines ..... 3
  - 1.2 Conventions ..... 3
  - 1.3 Features and Technical Data ..... 4
  - 1.4 Main Applications ..... 4
  
- 2 OVERVIEW ..... 5**
  
- 3 CONNECTIONS ..... 6**
  - 3.1 Ethernet LAN 1A – D ..... 6
  - 3.2 Ethernet LAN 2 ..... 6
  - 3.3 Serial Port COM1 ..... 7
  - 3.4 Serial Port COM2 ..... 8
  - 3.5 Power Supply ..... 9
  - 3.6 Semiconductor Relay Output ..... 10
  
- 4 HELPFUL LITERATURE ..... 11**
  
- CONTACT ..... 11**
  
- DOCUMENT HISTORY ..... 11**

# 1 INTRODUCTION

---

This document describes the hardware components and the necessary cable connections of the Remote Access Gateway IGW/925.

## 1.1 Safety Guidelines

---

Please read the following safety guidelines carefully! In case of property or personal damage by not paying attention to this document and/or by incorrect handling, we do not assume liability. In such cases any warranty claim expires.

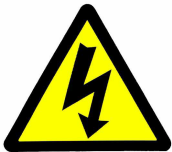

**ATTENTION:** Observe precautions for handling – electrostatic sensitive device!

- Discharge yourself before you work with the device, e.g. by touching a heater of metal, to avoid damages.
- Stay grounded while working with the device to avoid damage through electrostatic discharge.

## 1.2 Conventions

---

Convention	Usage
<b>bold</b>	Important terms
<i>italic</i>	Filenames, user inputs and command lines
monospace	Pathnames, internet addresses and program code

**Table 1: Conventions used in this document**

## 1.3 Features and Technical Data

<b>Processor</b>	
<b>Manufacturer / Type</b>	Atmel AT91RM9200 32-bit ARM9-MCU (DIL/NetPC ADNP/9200 on QIL-128 socket)
<b>Clock speed</b>	180 MHz
<b>Memory</b>	
<b>RAM</b>	64 MB SDRAM
<b>Flash</b>	32 MB NOR memory
<b>Interfaces</b>	
<b>Ethernet</b>	1x 10/100 Mbps (RJ45) 4x 10/100 Mbps (RJ-45) over integrated 4-port switch with Auto MDI-X support
<b>Serial I/Os</b>	1x RS232 serial port with handshake (Sub-D) 1x RS232/RS485 serial port with software-selectable mode switch (screw terminal)
<b>Alarm output</b>	1x Semiconductor relay output (max. 30 VDC, 500 mA)
<b>Special Functions</b>	
<b>RTC</b>	1x Real Time Clock with battery-backup (CR1225 Lithium 3 V)
<b>Watchdog</b>	1x Timer watchdog (hardware-based, software-configurable) 1x Power supervisor (hardware-based)
<b>Expansion</b>	1x internal 80-pin ESL connector for GSM/GPRS, UMTS/HSPA or WiFi add-on
<b>Displays / Control Elements</b>	
<b>LEDs</b>	1x Power 1x IGW start-up + VPN status (programmable) 1x LAN LED for Ethernet interface LAN 1A - D 2x LAN LED for Ethernet interface LAN 2
<b>Electrical Characteristics</b>	
<b>Power supply</b>	12 .. 24 VDC (typ. 24 VDC) from external power supply
<b>Power consumption</b>	< 3 W
<b>Mechanical Characteristics</b>	
<b>Protection class</b>	IP20 industrial case for 35 mm DIN-rail mounting
<b>Mass</b>	< 270 g
<b>Dimensions</b>	112 mm x 100 mm x 45 mm
<b>Operating temperature</b>	0 .. 70 °C
<b>Standards and Certifications</b>	
<b>EMC</b>	CE
<b>Environmental standards</b>	RoHS, WEEE
<b>Industrial standards</b>	VHPready (Virtual Heat & Power Ready)

## 1.4 Main Applications

- Remote Access Security Gateway
- GPRS/UMTS Router
- Industrial Firewall
- Application Gateway
- Proxy Server
- VPN Gateway / Router
- Linux Device Server

## 2 OVERVIEW

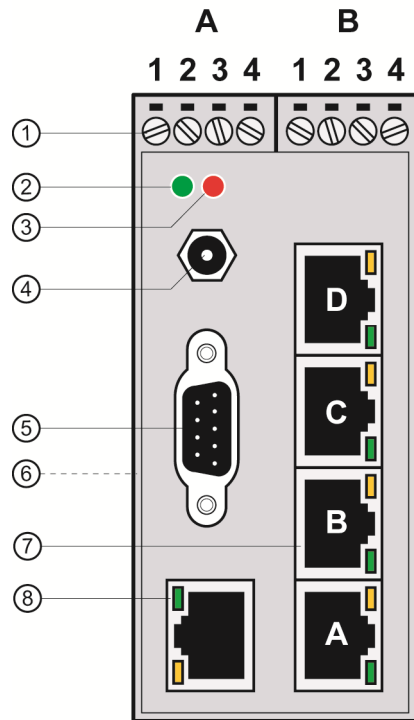

- |                                  |                                |
|----------------------------------|--------------------------------|
| ① Screw terminals A1- 4 and B1-4 | ⑤ Serial port COM1             |
| ② Power LED                      | ⑥ DIN-rail mounting (backside) |
| ③ User LED (programmable)        | ⑦ Ethernet interface LAN 1A-D  |
| ④ Antenna connector (GSM/UMTS)   | ⑧ Ethernet interfaces LAN 2    |

**Figure 1: Overview Remote Access Gateway IGW/925**

## 3 CONNECTIONS

### 3.1 Ethernet LAN 1A – D

The Ethernet interfaces LAN 1A – D offer each a green LED. It is on when there is a LAN link established and blinks when there is traffic. The yellow LED is not connected.

The Ethernet interfaces LAN 1A – D are equal. They are connected over an integrated 4-port switch.

The Ethernet interfaces LAN 1A – D support Auto MDI/MDIX.

Pin	Name	Function
1	TX+	10/100 Mbps LAN, TX+ Pin
2	TX-	10/100 Mbps LAN, TX- Pin
3	RX+	10/100 Mbps LAN, RX+ Pin
4	---	Not Connected
5	---	Not Connected
6	RX-	10/100 Mbps LAN, RX- Pin
7	---	Not Connected
8	---	Not Connected

Table 2: Pinout Ethernet interfaces LAN 1A – D



### 3.2 Ethernet LAN 2

The Ethernet LAN 2 interface offers a green LED. It is on when there is a LAN link established and blinks when there is traffic. The yellow LED is not connected.

The Ethernet interface LAN 2 does NOT support Auto MDI/MDIX.

Pin	Name	Function
1	TX+	10/100 Mbps LAN, TX+ Pin
2	TX-	10/100 Mbps LAN, TX- Pin
3	RX+	10/100 Mbps LAN, RX+ Pin
4	---	Not Connected
5	---	Not Connected
6	RX-	10/100 Mbps LAN, RX- Pin
7	---	Not Connected
8	---	Not Connected

Table 3: Pinout Ethernet interface LAN 2

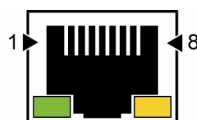

### 3.3 Serial Port COM1

The serial port COM1 is a standard Sub-D connector.

Pin	Name	Function
1	DCD	COM1 Serial Port, DCD pin (RS232)
2	RXD	COM1 Serial Port, RXD pin (RS232)
3	TXD	COM1 Serial Port, TXD pin (RS232)
4	DTR	COM1 Serial Port, DTR pin (RS232)
5	GND	Ground
6	DSR	COM1 Serial Port, DSR pin (RS232)
7	RTS	COM1 Serial Port, RTS pin (RS232)
8	CTS	COM1 Serial Port, CTS pin (RS232)
9	DCD	COM1 Serial Port, DCD pin (RS232)

**Table 4: Pinout COM1 connector**

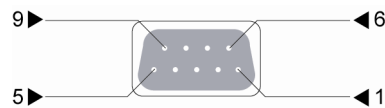

### 3.4 Serial Port COM2

To create an RS232 serial link on port COM2 of the Remote Access Gateway IGW/925 connect the adapter cable and the null-modem cable like shown in the figure below.

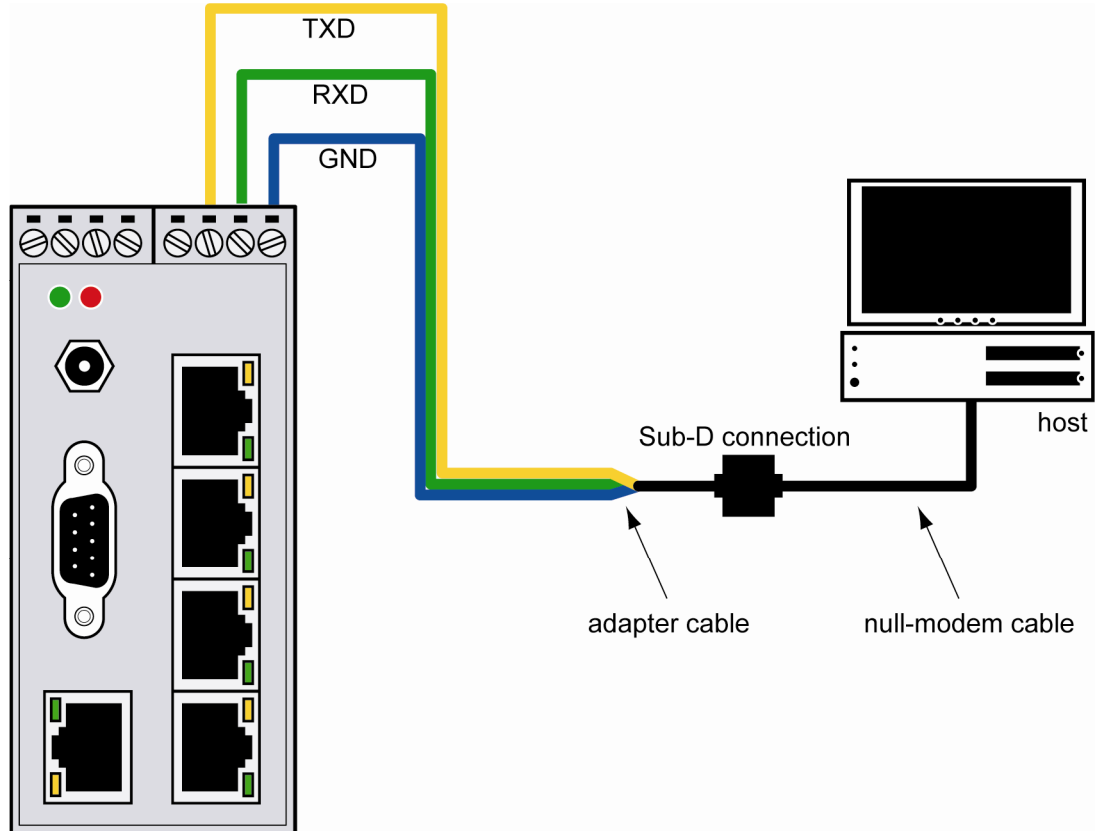

Figure 2: RS232 link on serial port COM2

Terminal	Signal
B2	COM2 Serial Port: TXD (RS232), RX/TX- (RS485)
B3	COM2 Serial Port: RXD (RS232), RX/TX+ (RS485)
B4	Ground

Table 5: Screw terminal COM2



### 3.5 Power Supply

The Remote Access Gateway IGW/925 needs a supply voltage of 11 .. 28 VDC to work. Use the power adapter cable to provide the system with the necessary power like shown in the figure below.

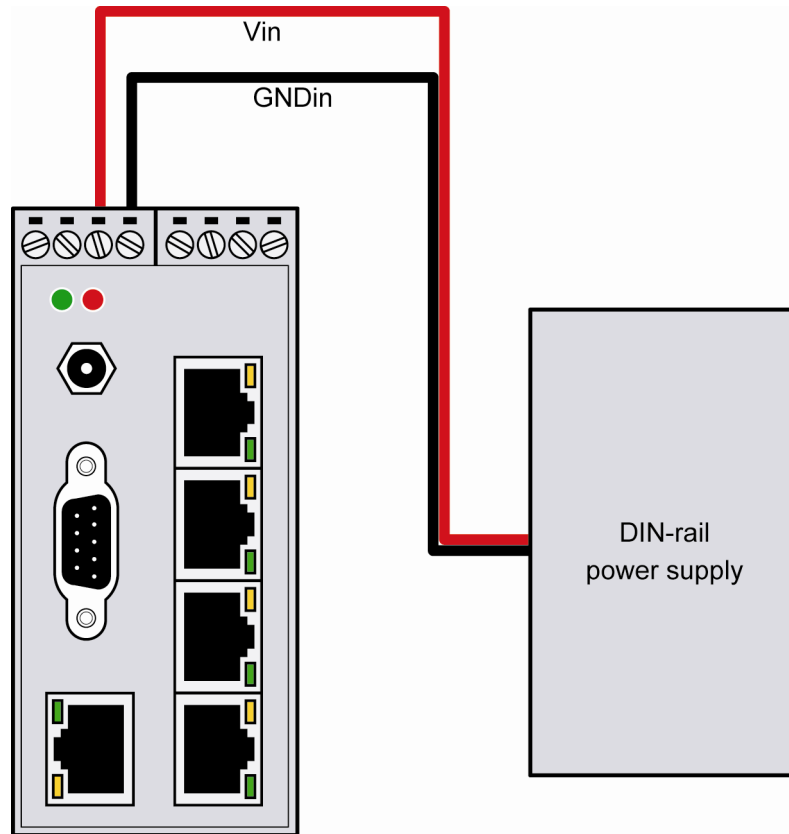
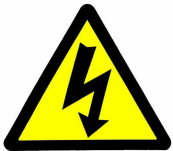

Figure 3: Power supply for the Remote Access Gateway IGW/925

Terminal	Signal
A3	Vin (11 .. 28 VDC)
A4	GNDin

Table 6: Screw terminal power



**CAUTION:** Providing the Remote Access Gateway IGW/925 with a higher voltage than the regular 11 .. 28 VDC  $\pm 10\%$  could cause damaged board components!

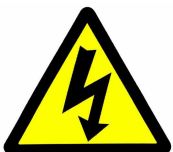

**CAUTION:** Do NOT turn on the power supply while connecting the power adapter cable with the Remote Access Gateway IGW/925. This could cause damaged board components! First connect the power adapter cable and THEN turn the power supply on.

### 3.6 Semiconductor Relay Output

The Remote Access Gateway IGW/925 offers a semiconductor relay output to switch an external alarm device with up to 30 VDC and 500 mA on and off.

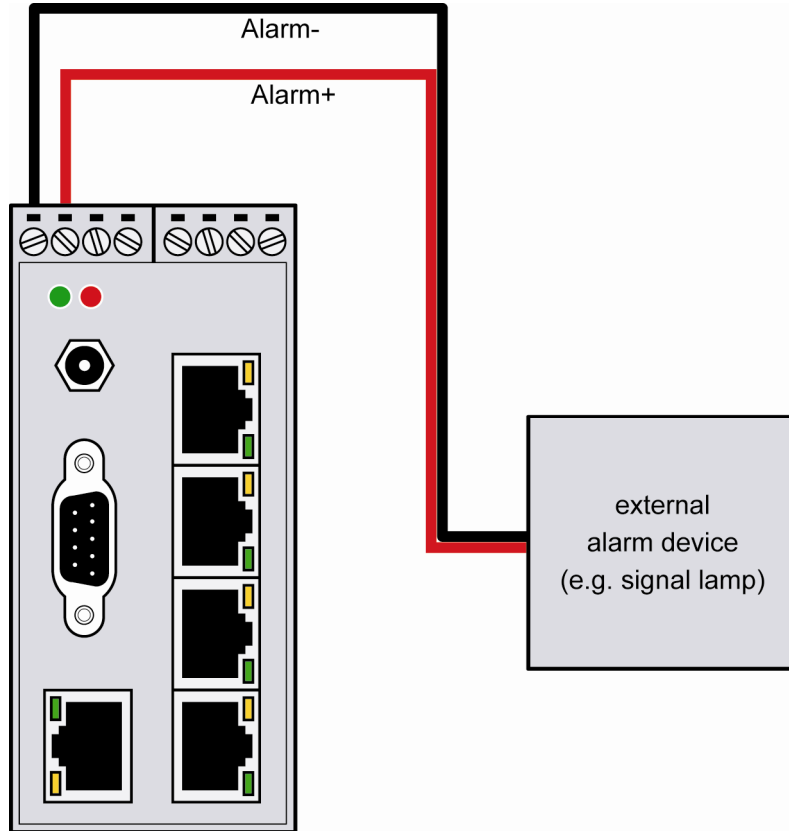
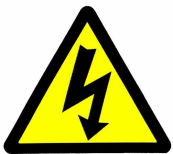

Figure 4: Connecting an external alarm device

Terminal	Signal
A1	Alarm- Semiconductor Relay Output (max. 30 VDC / 500 mA)
A2	Alarm+ Semiconductor Relay Output (max. 30 VDC / 500 mA)

Table 7: Screw terminal semiconductor relay output



**CAUTION:** Using the alarm output with more than the regular 30 VDC and 500 mA could cause damaged board components!

## 4 HELPFUL LITERATURE

---

- DIL/NetPC ADNP/9200 hardware reference
- SSV Web ConfigTool User Manual

## CONTACT

---

### SSV Embedded Systems

Dünenweg 5  
D-30419 Hannover

Phone: +49 (0)511/40 000-0  
 Fax: +49 (0)511/40 000-40  
 E-mail: sales@ssv-embedded.de

Internet: [www.ssv-embedded.de](http://www.ssv-embedded.de)  
 Forum: [www.ssv-comm.de/forum](http://www.ssv-comm.de/forum)

## DOCUMENT HISTORY

---

Revision	Date	Remarks	Name	Review
1.0	2011-11-01	First version	WBU	FKI
1.1	2012-01-16	Warning added in chapter 3.5	WBU	FKI
1.2	2013-01-28	Changed names of LAN ports	WBU	FKI
1.3	2013-07-29	Changed cover image, edited figure 1	WBU	FKI
1.4	2013-08-20	Added Auto MDI/MDIX support in chapters 1.3 and 3.1	WBU	FKI
1.5	2015-08-26	edited chapter 1.3	WBU	FKI

The content of this document can change any time without announcement. There is taken over no guarantee for the accuracy of the statements. The user assumes the entire risk as to the accuracy and the use of this document. Information in this document is provided 'as is' without warranty of any kind. Some names within this document can be trademarks of their respective holders.

© 2015 SSV EMBEDDED SYSTEMS. All rights reserved.